

Transformacija

Z veliko denarja je enostavno opremiti prostor. Kaj pa, če tega denarja ni in se mora življenje nadaljevati?
Kaj pa, če imamo le kup starih desk iz razrezanega paviljona bienala, nekaj mizarskega orodja in prazen prostor, ki ga je treba spremeniti v večnamensko učilnico?
Ali imamo voljo za kaj takega ali stari rek - desperation makes inspiration - ne velja več?
In čisto nepričakovano v nas se je prebudil duh naših babic, ki so iz starih plaščev izdelovale hlače, plašče, krila, klobuke ...
Zavihali smo rokave in šli v akcijo!

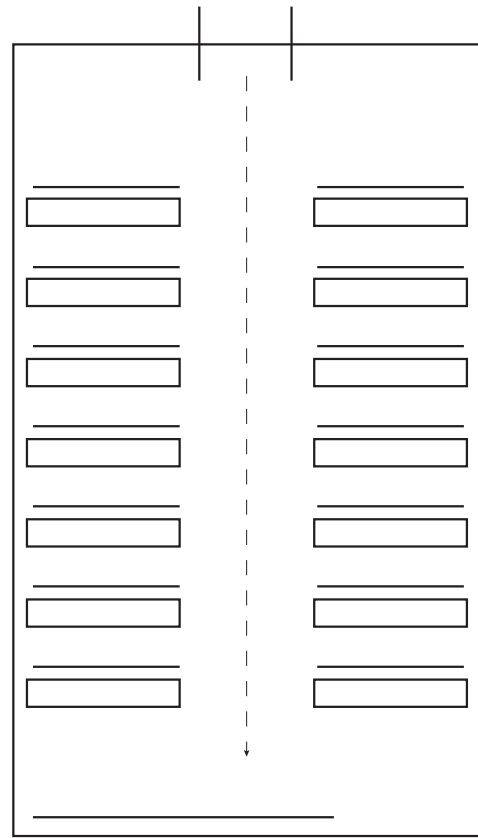

fabijanijeva predavalnica

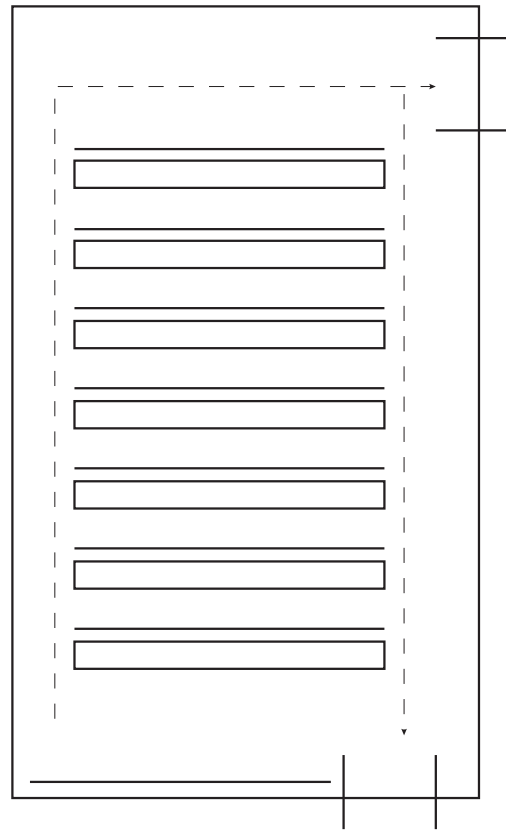

vurnikova predavalnica

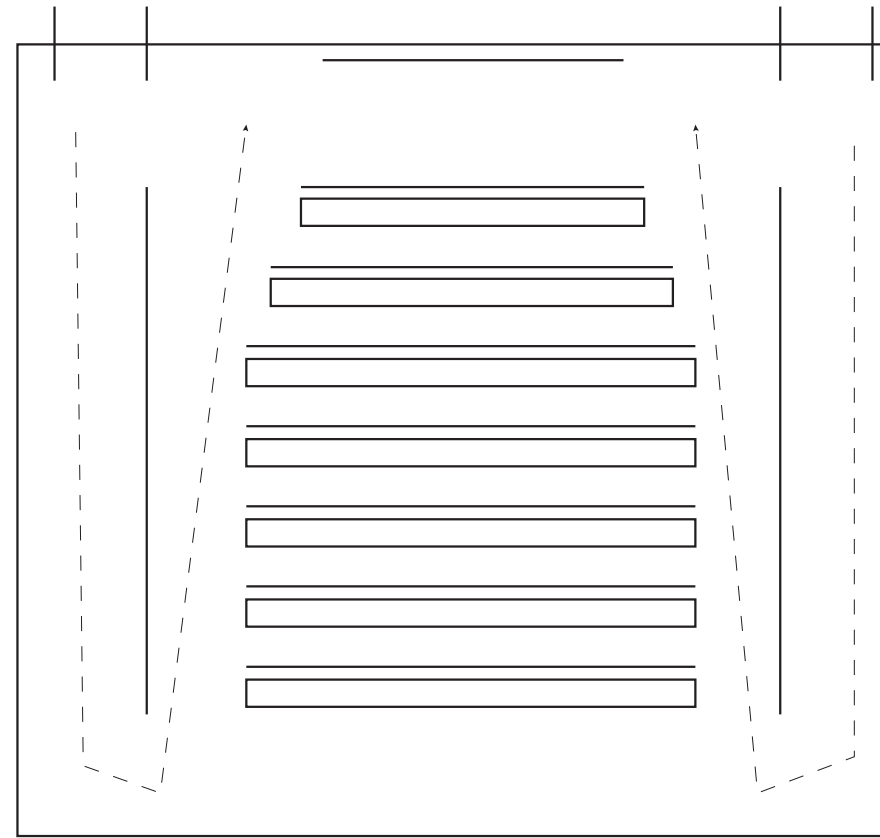

plečnikova predavalnica

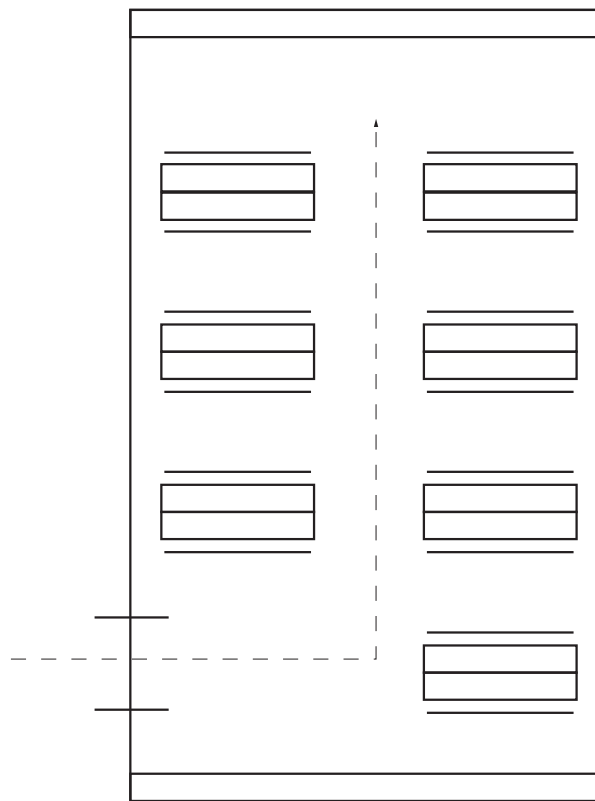

seminar - prezentacija +

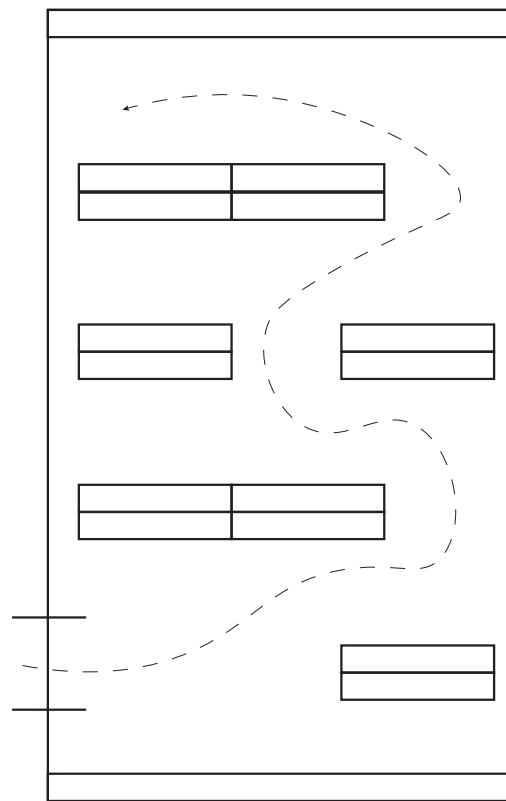

seminar - razstava +

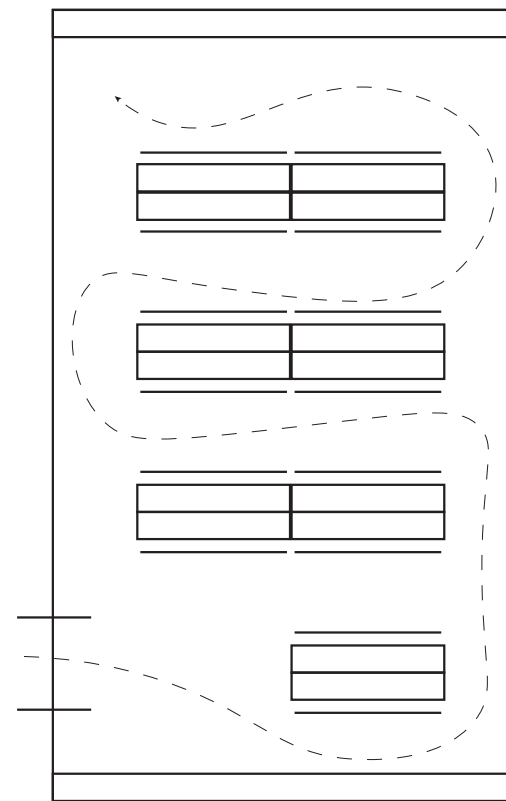

seminar - delo

Transformacija

=

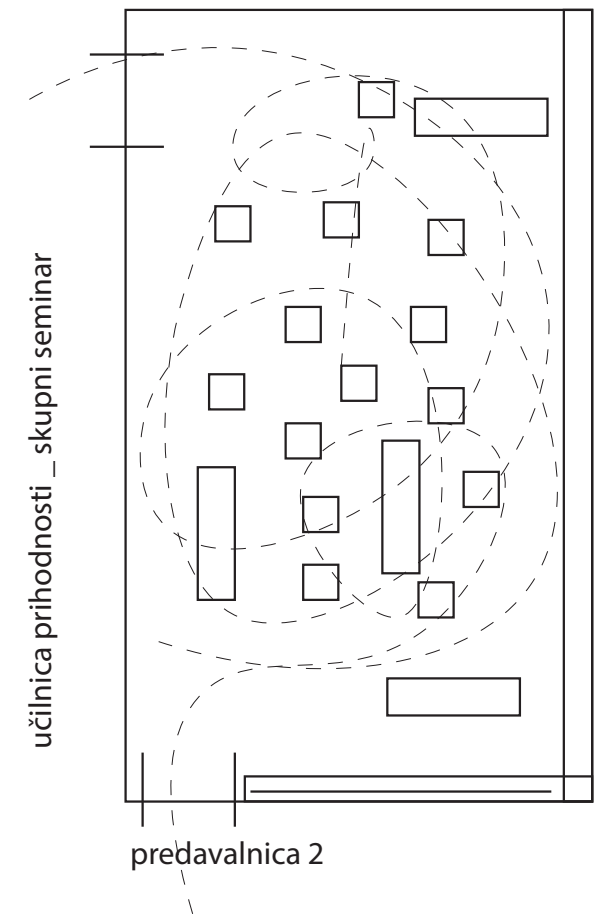

učilnica prihodnosti _ skupni seminar

predavalnica 2

Kup starih desk smo najprej razvrstili po vrsti in velikosti. Že na prvi pogled je bilo jasno, da imamo dovolj materiala za stole in mize, ne pa tudi za police, ki jih bomo zagotovo potrebovali za razstavo seminarских del ob koncu leta. Ta problem nas je pripeljal do ideje, da bi lahko police naredili iz stolov, če bi najdli način, da jih preprosto zložimo skupaj.

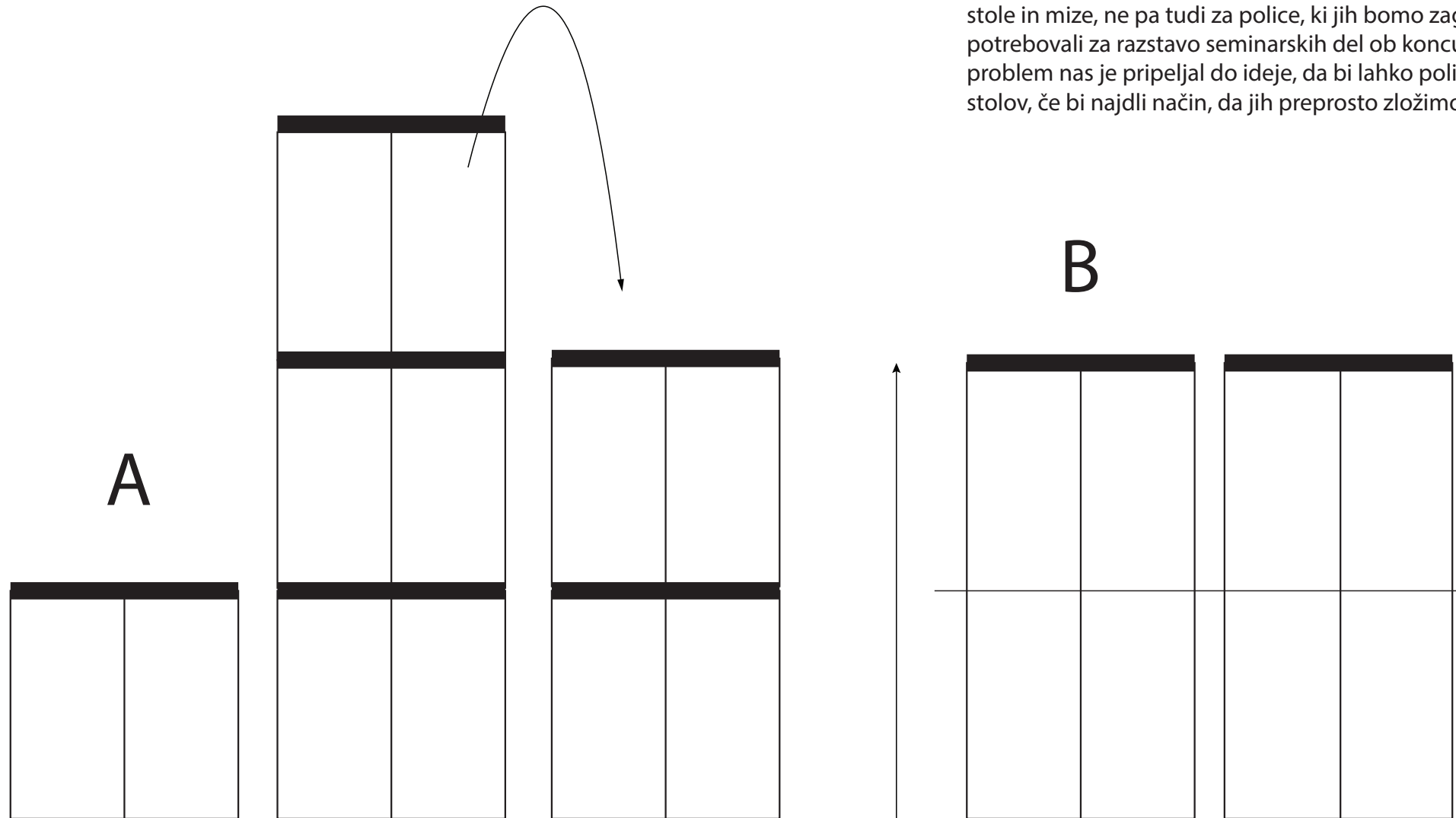

natečaj: študijsko
okolje prihodnosti

Fakulteta za arhitekturo

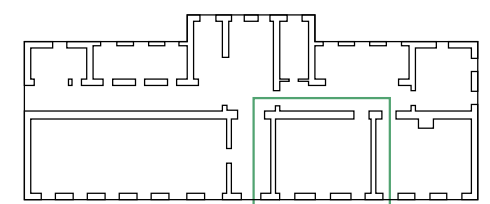
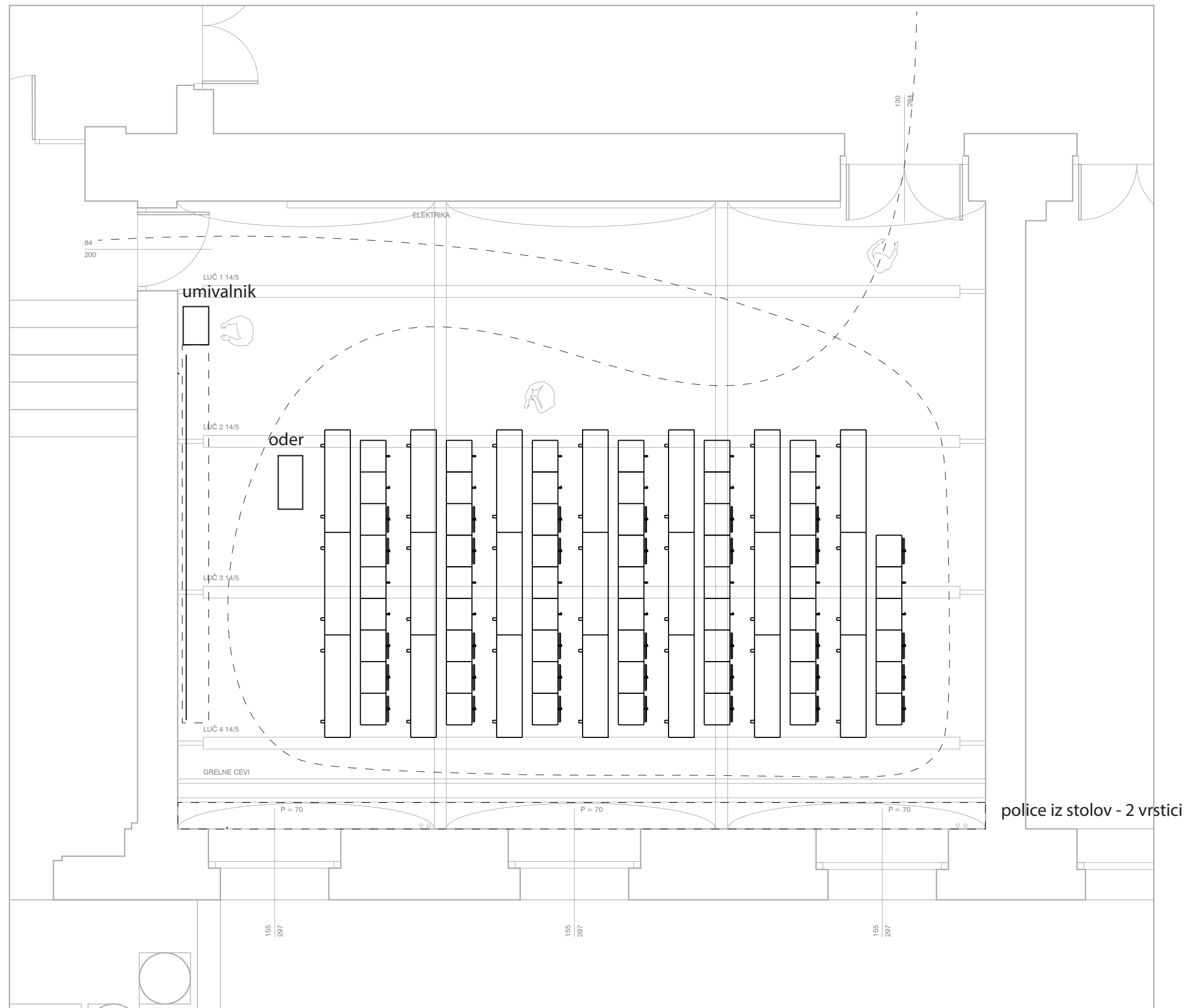

vrsta risbe	tloris
opis	predavanje
merilo	1:50
datum	julij 2022

natečaj: študijsko
okolje prihodnosti

Fakulteta za arhitekturo

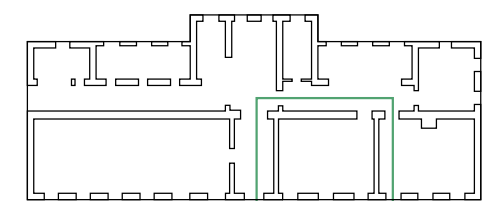
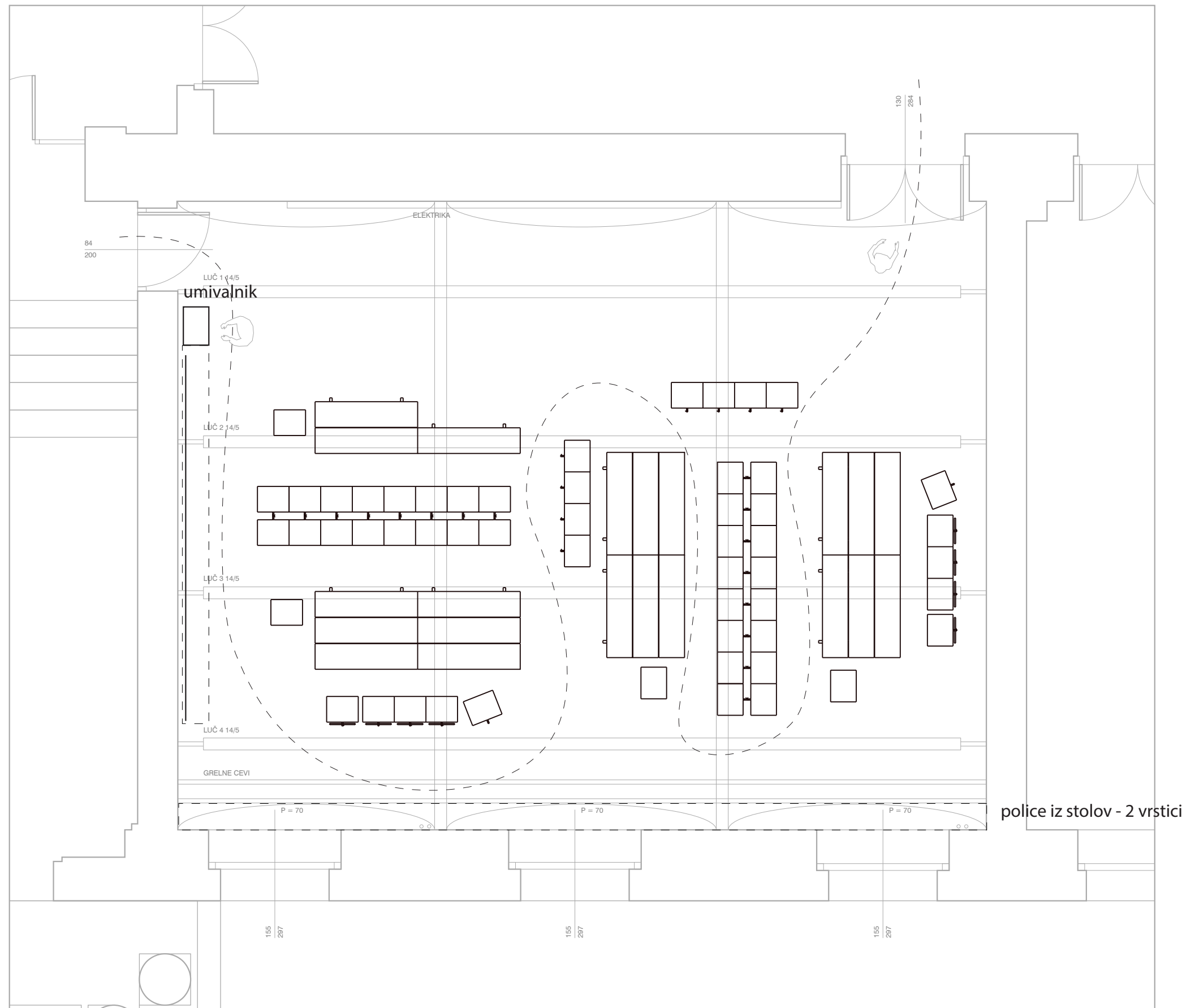

vrsta risbe	tloris
opis	delavnice
merilo	1:50
datum	julij 2022

natečaj: študijsko
okolje prihodnosti

Fakulteta za arhitekturo

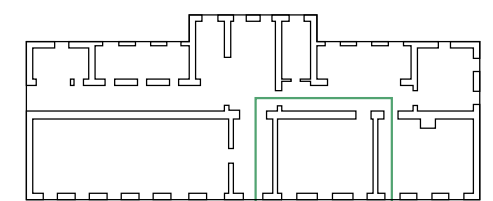
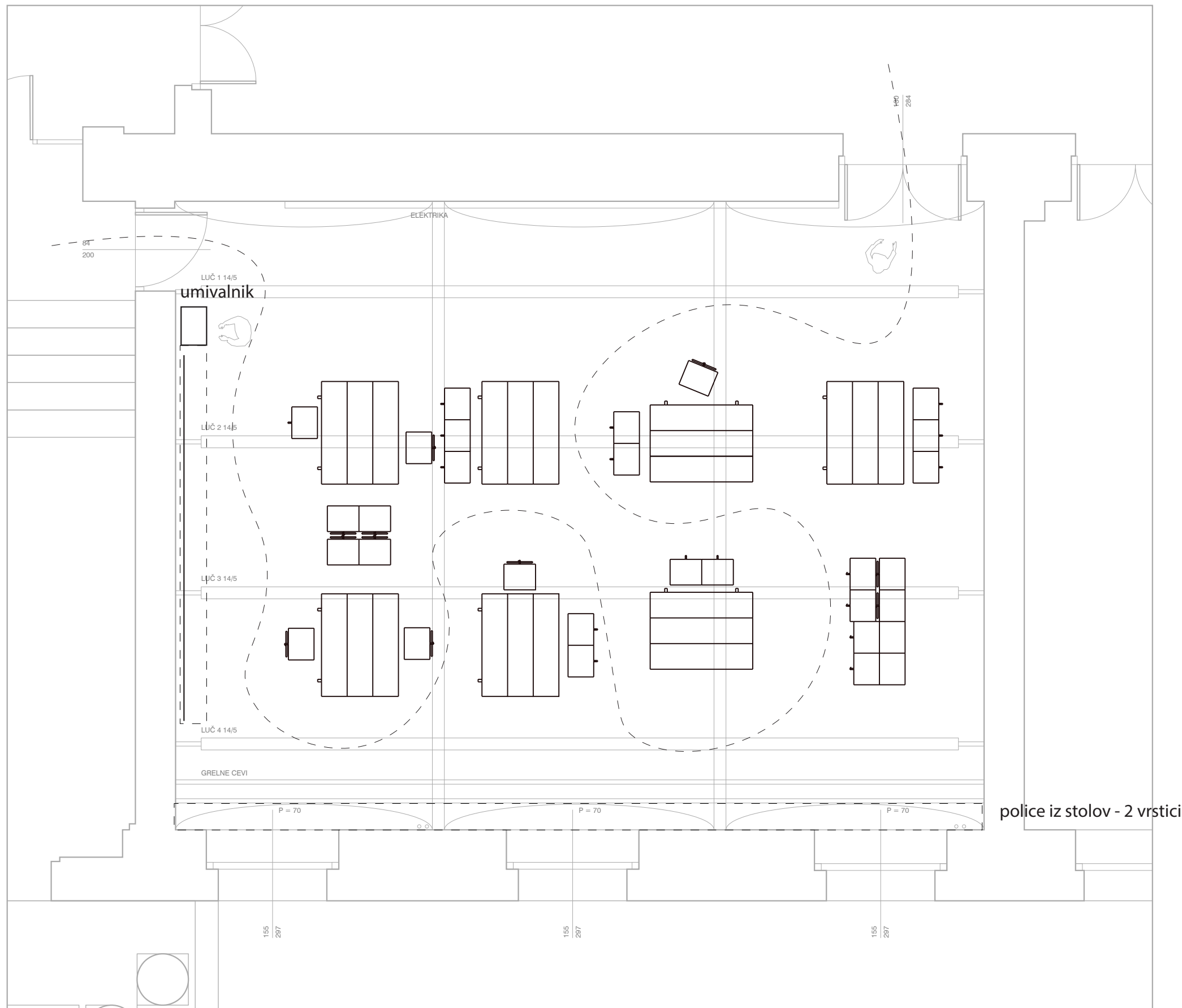

vrsta risbe	tloris
opis	individualno delo
merilo	1:50
datum	julij 2022

natečaj: študijsko
okolje prihodnosti

Fakulteta za arhitekturo

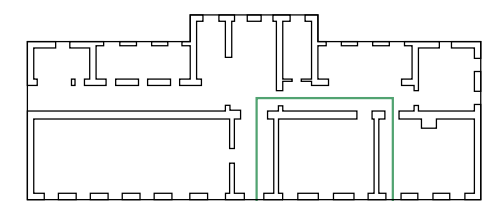
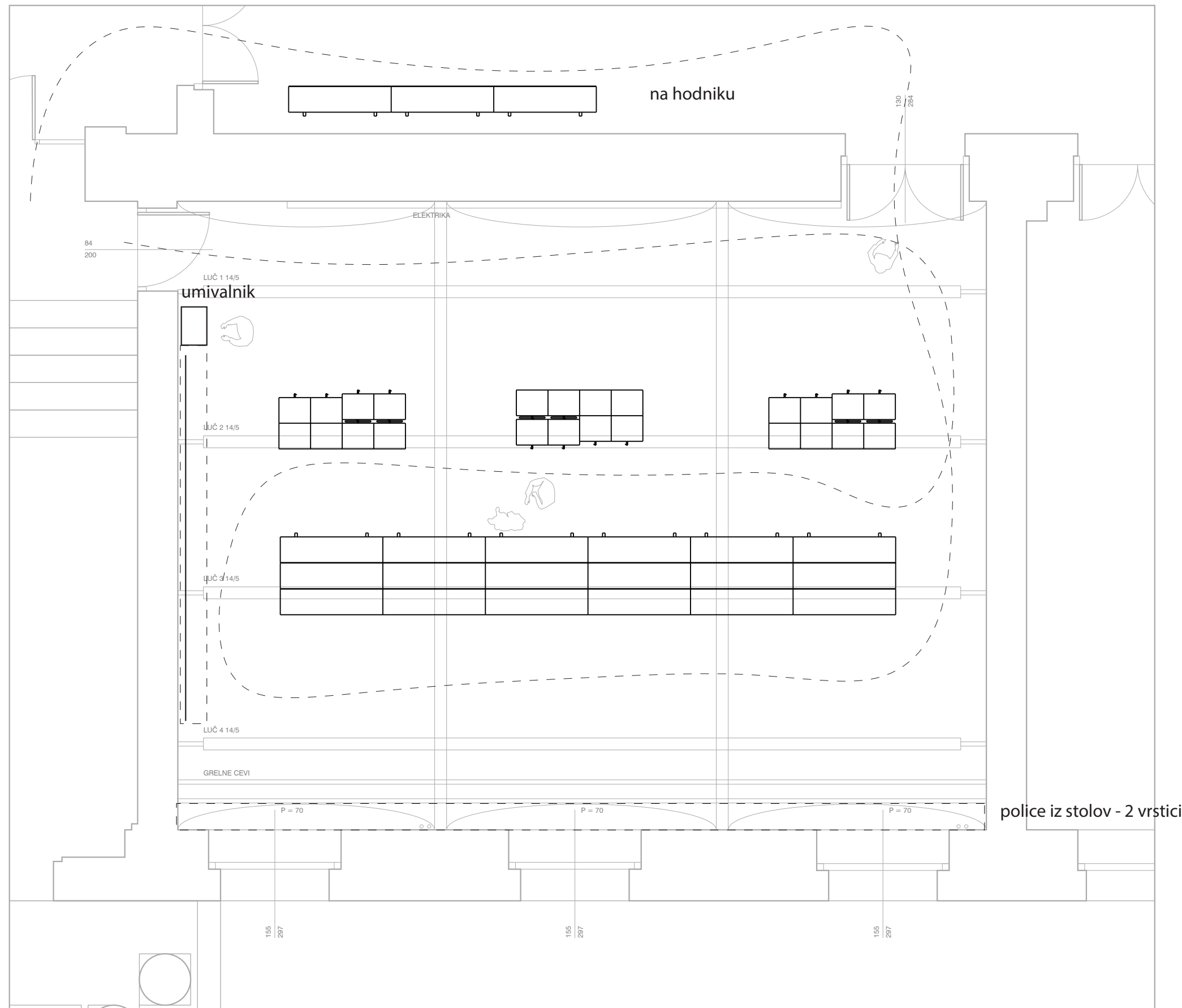

vrsta risbe	tloris
opis	razstavni prostor
merilo	1:50
datum	julij 2022

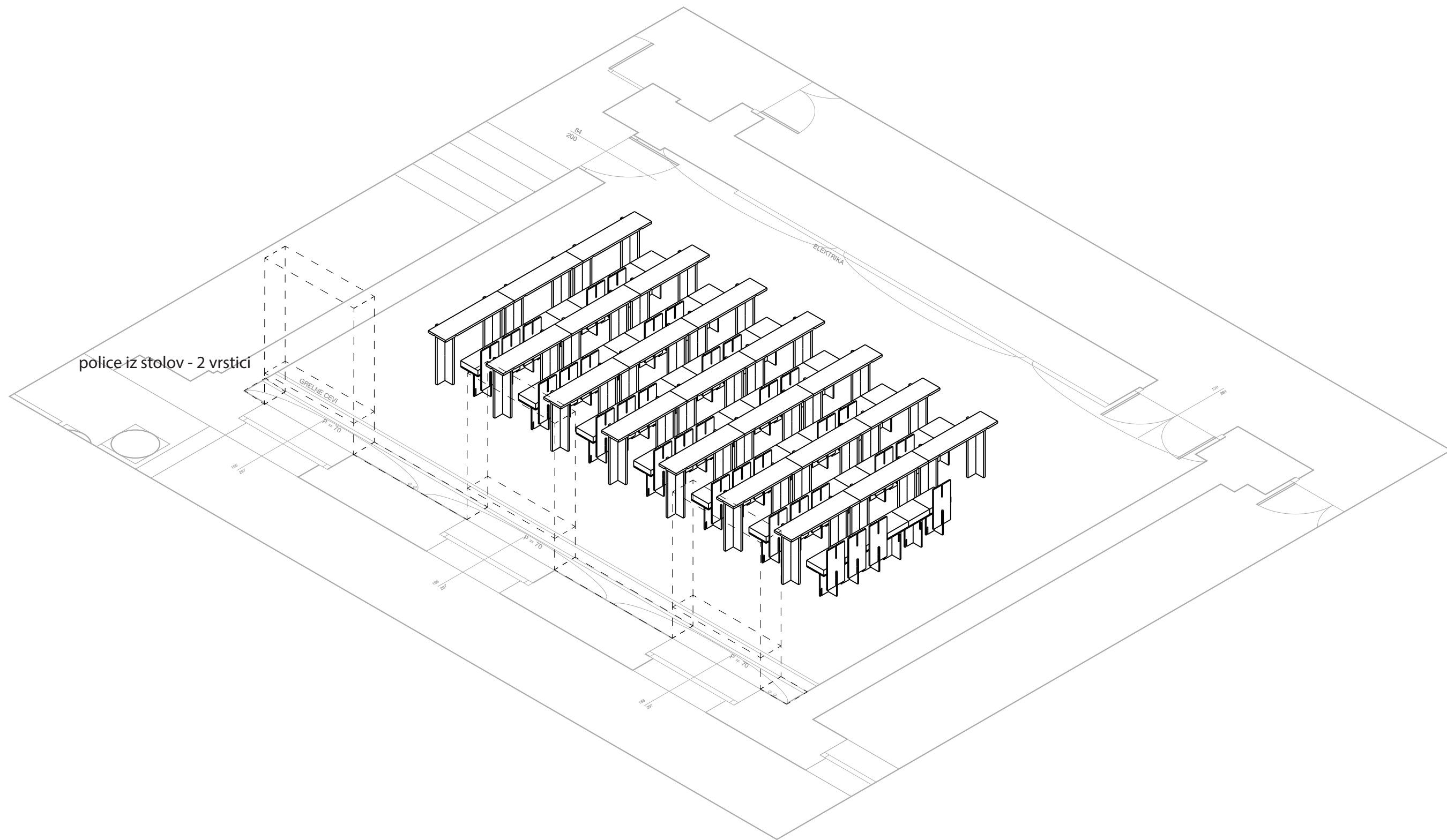

police iz stolov - 2 vrstici

GRELNE CEVI

p = 70

p = 70

p = 70

ELEKTRIKA

B4
200

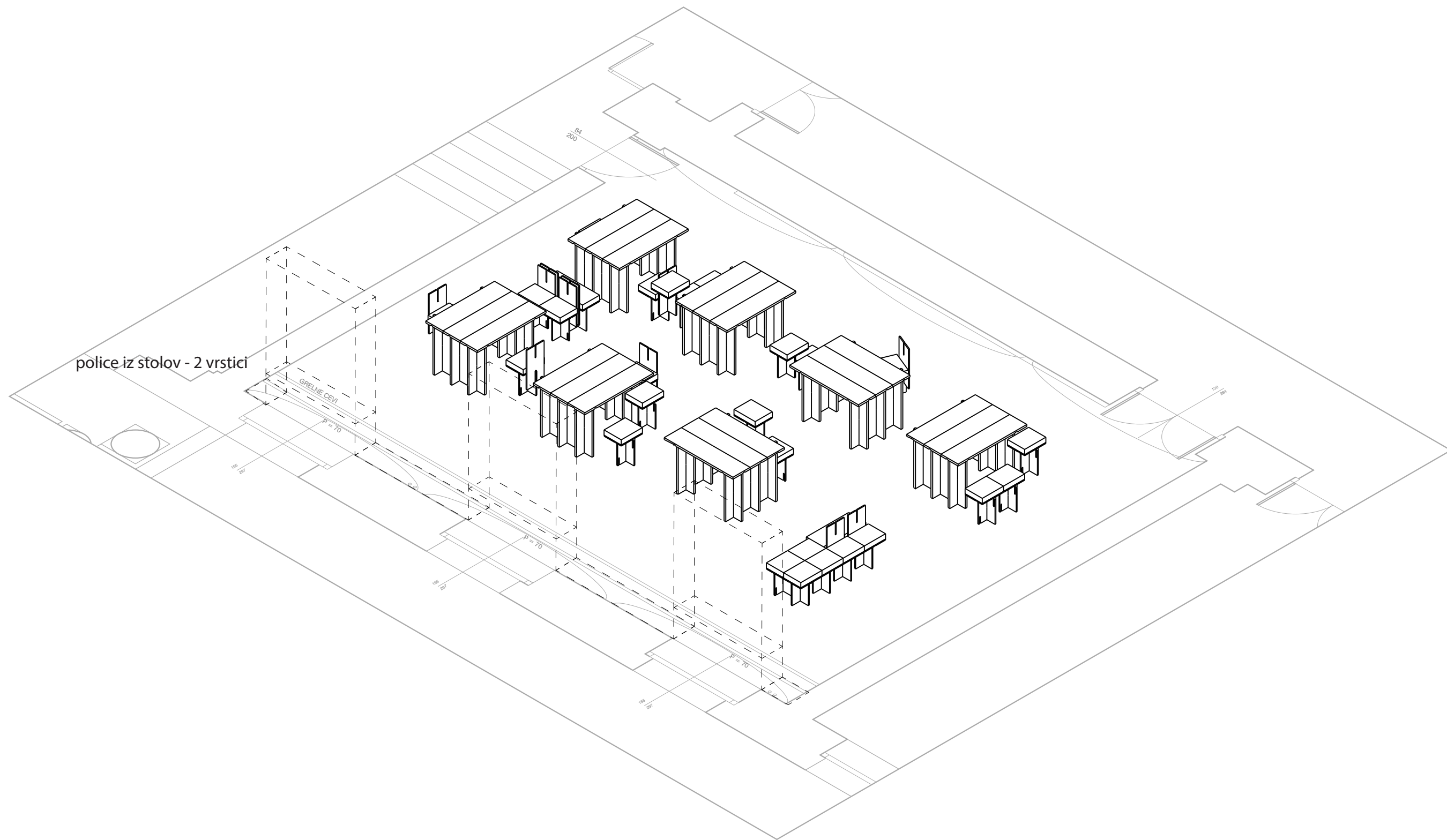

police iz stolov - 2 vrstici

GRELNE CEVI

p = 70

p = 70

p = 70

B4
200

B1
100

B2
100

B1
100

B2
100

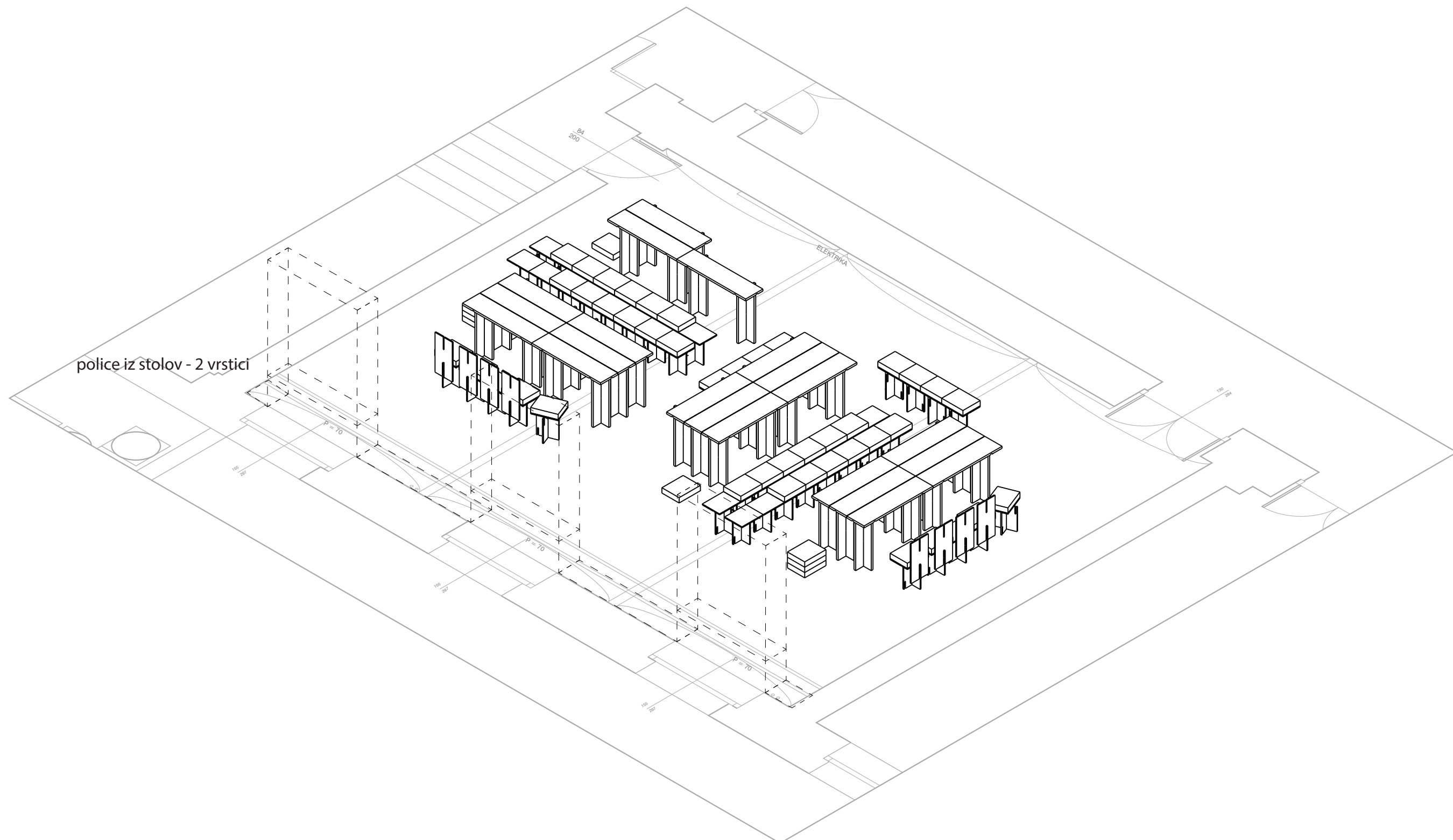

police iz stolov - 2 vrstici

ELEKTRIKA

B4
200

p = 70

p = 70

p = 70

p = 90

p = 90

p = 90

p = 90

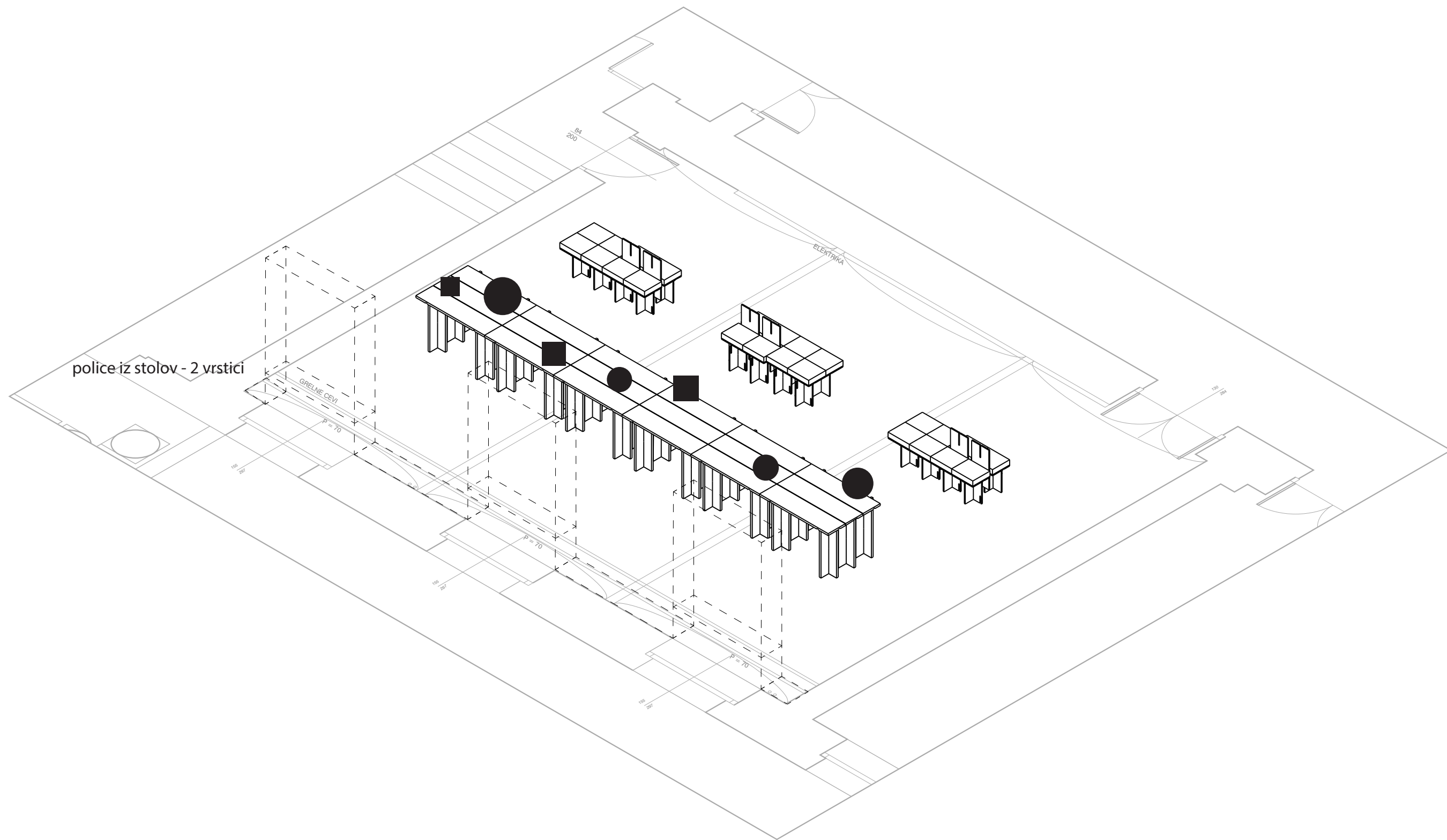

police iz stolov - 2 vrstici

GRELNE CEVI

ELEKTRIKA

BA
200

p = 70

p = 70

p = 70

p = 90

p = 90

p = 90

p = 90

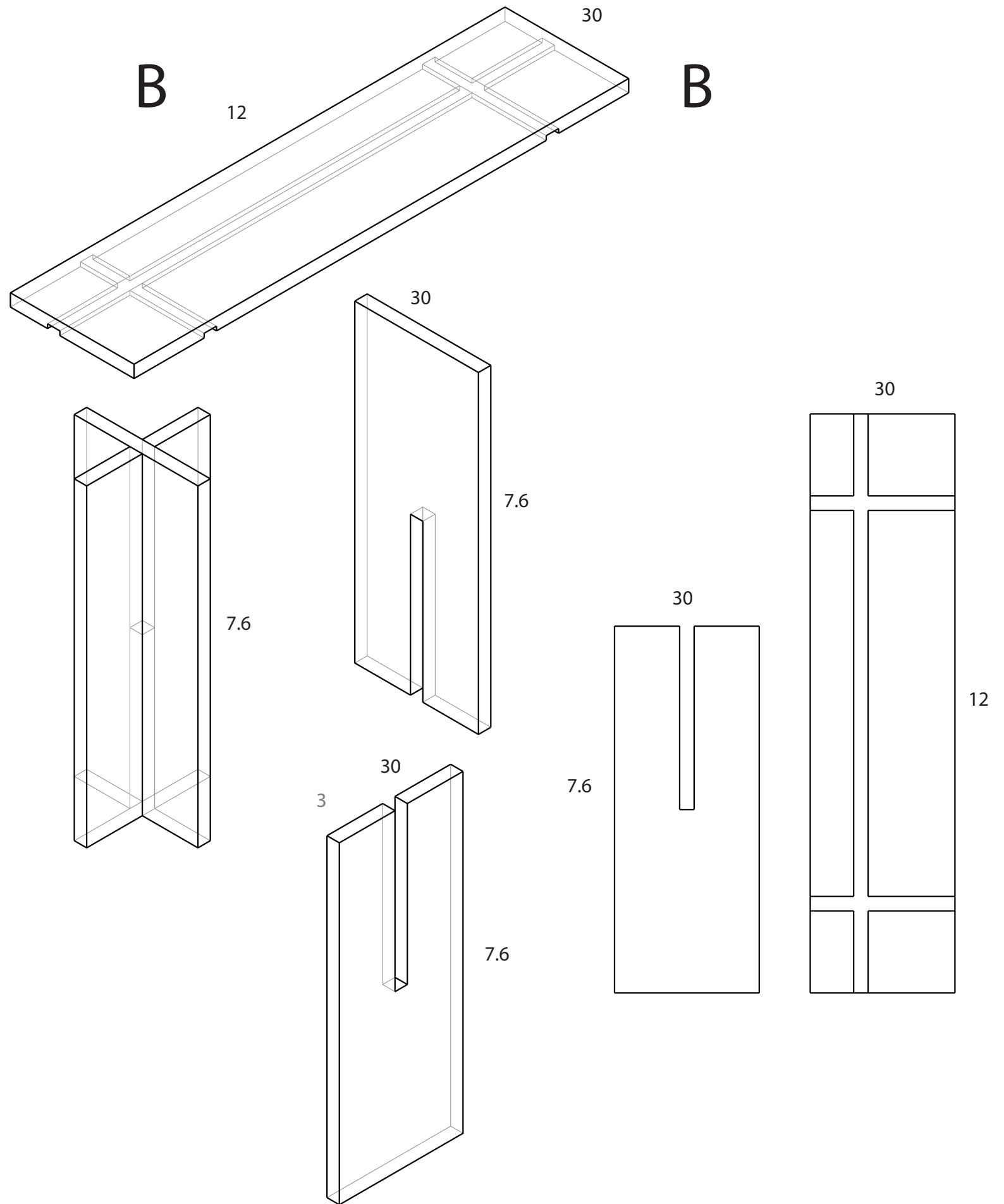
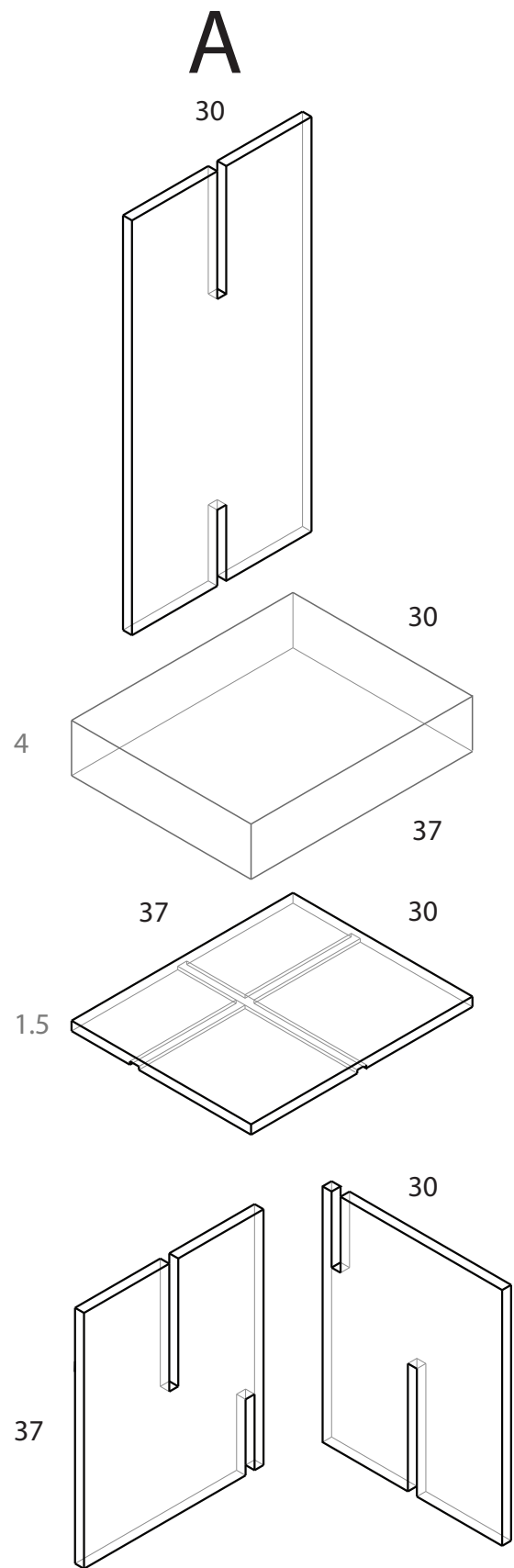
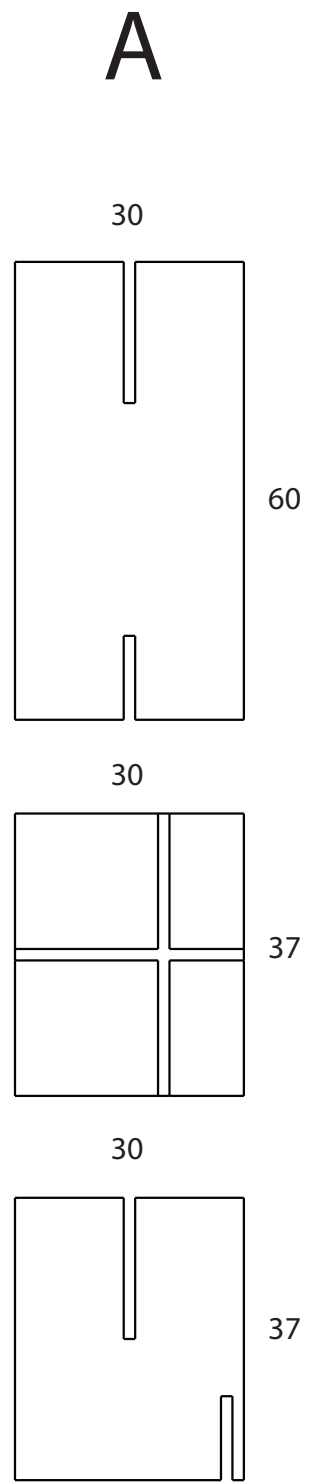

1:10

A

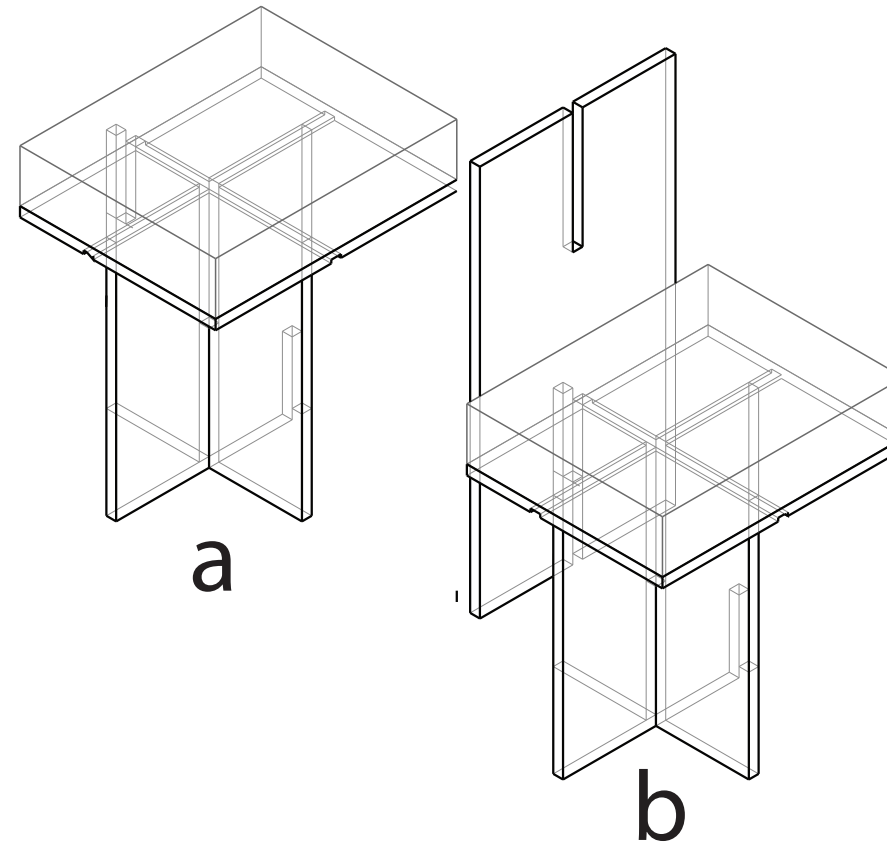
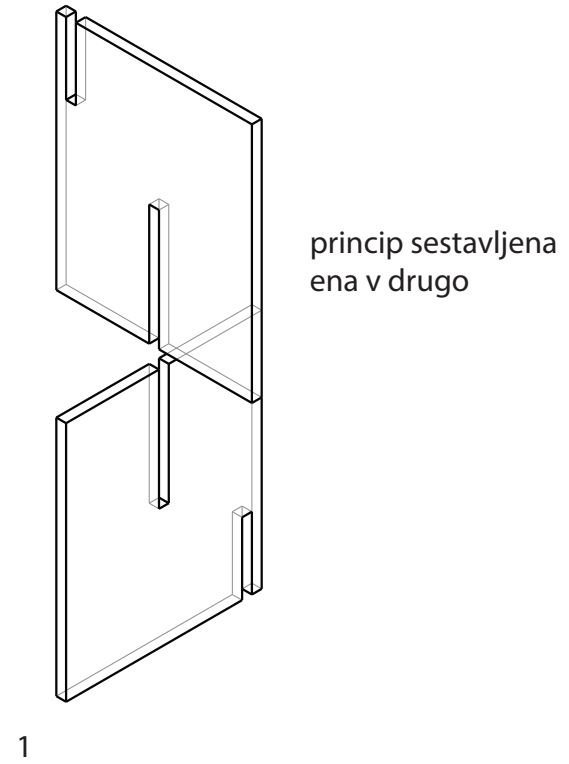
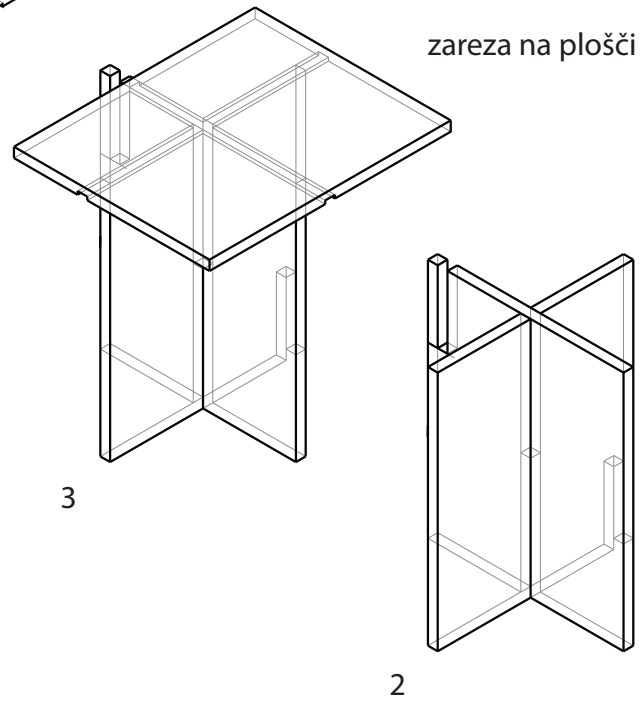
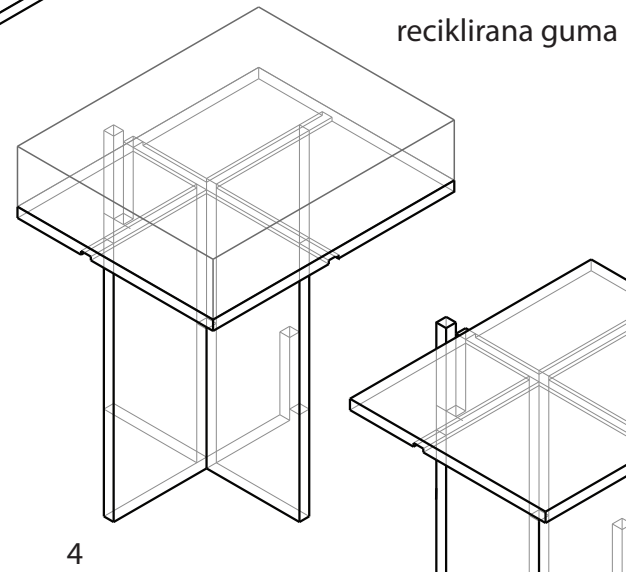
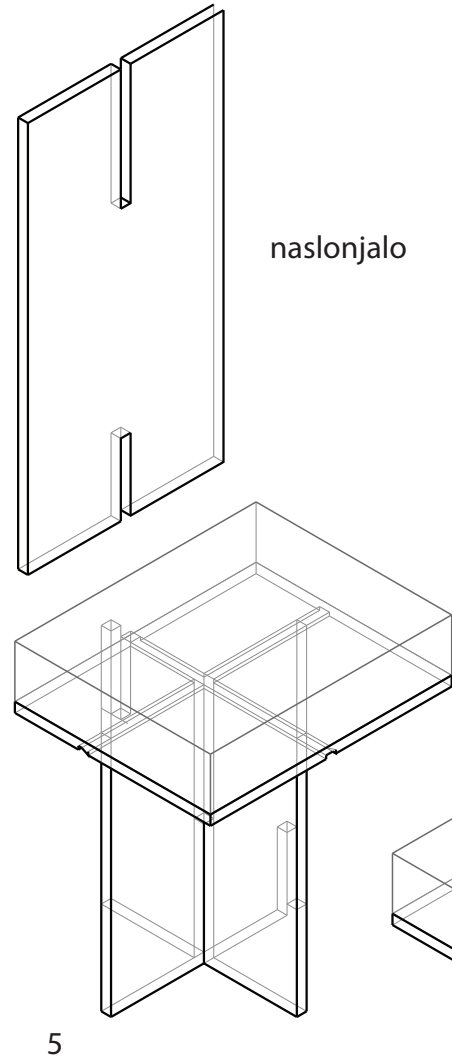

stol 1:10

A

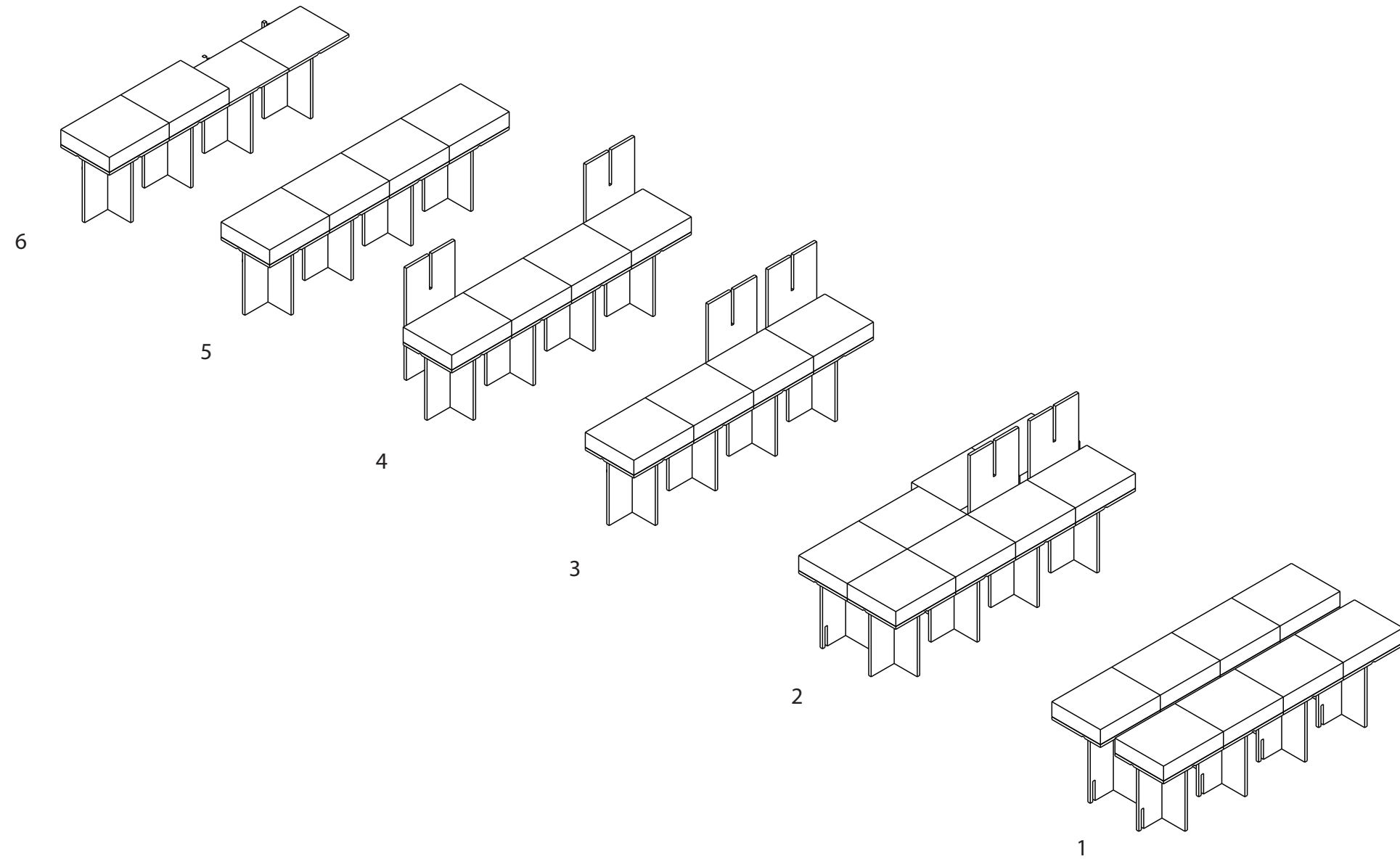

stol

B

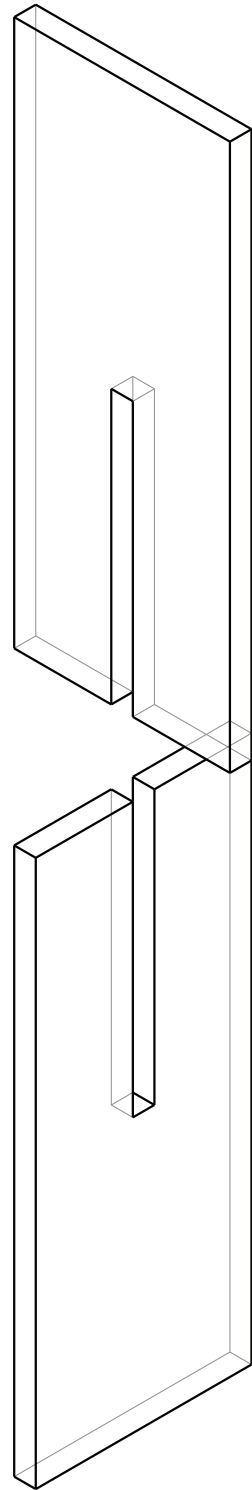

princip sestavljena
ena v drugo

1

miza 1:10

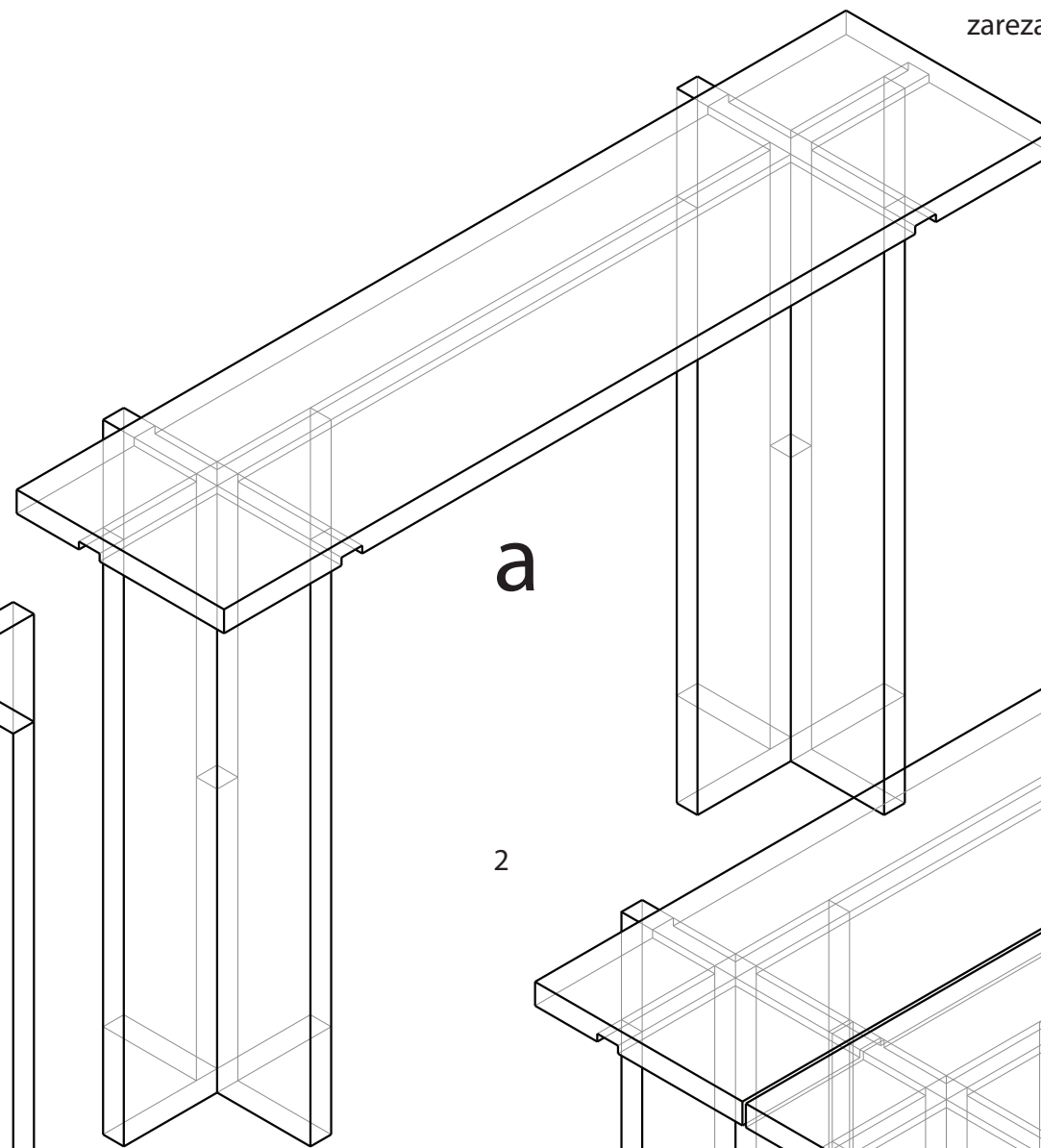
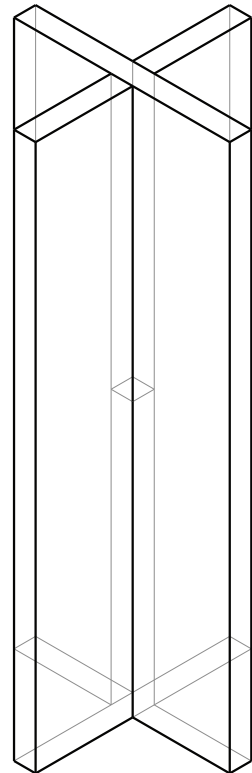

zareza na plošči

a

2

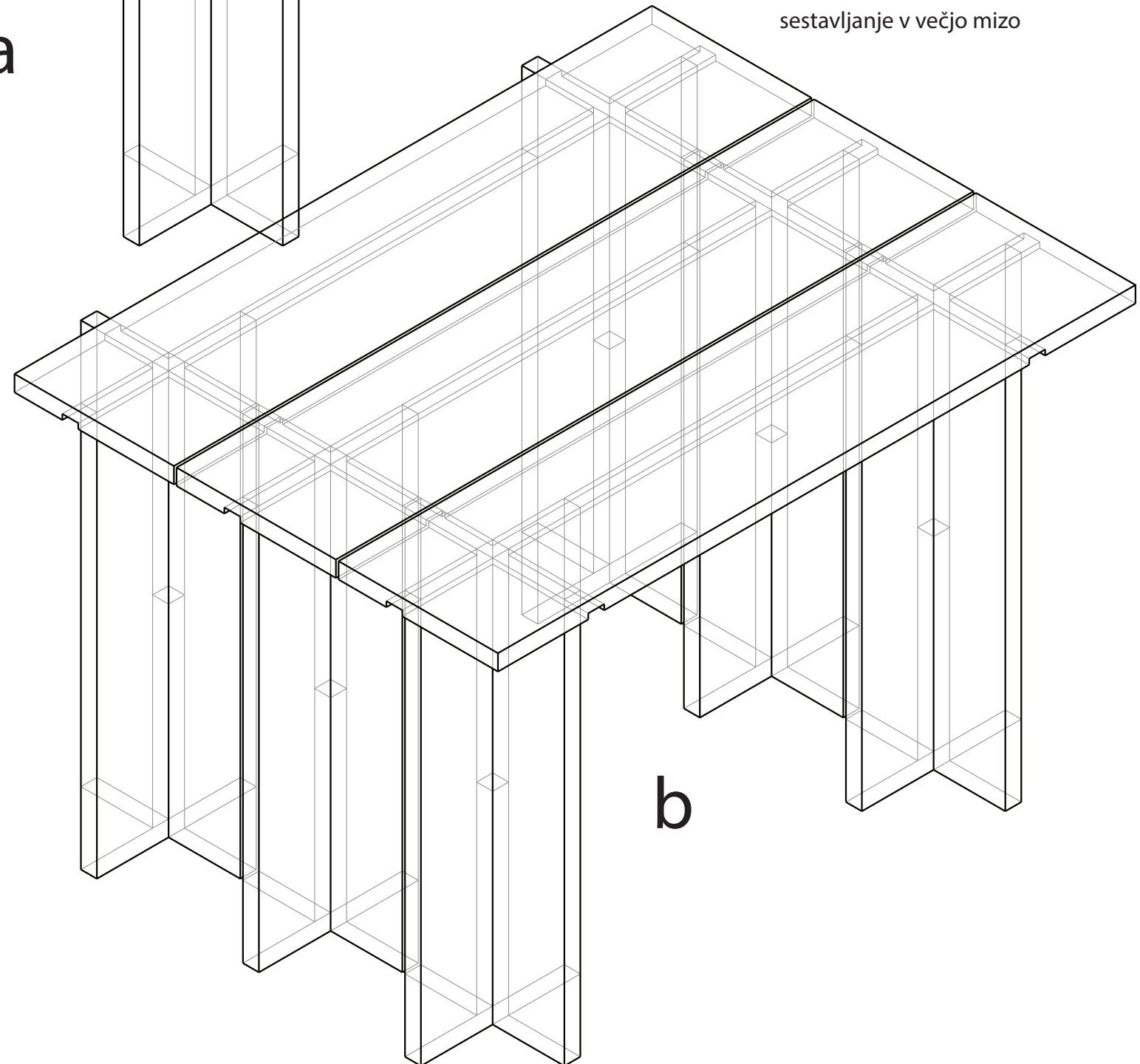

sestavljanje v večjo mizo

b

AB

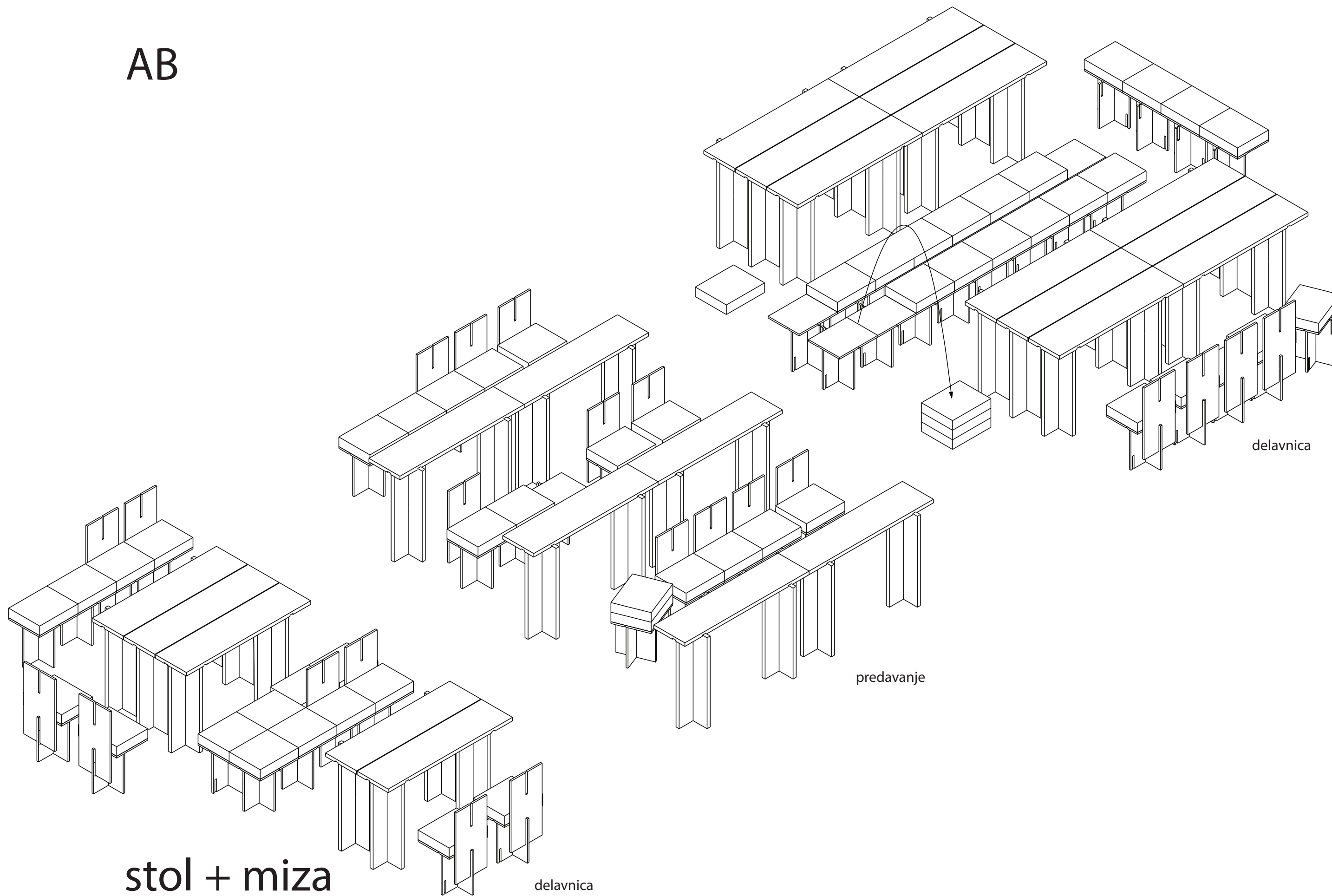

stol + miza

delavnica

predavanje

delavnica

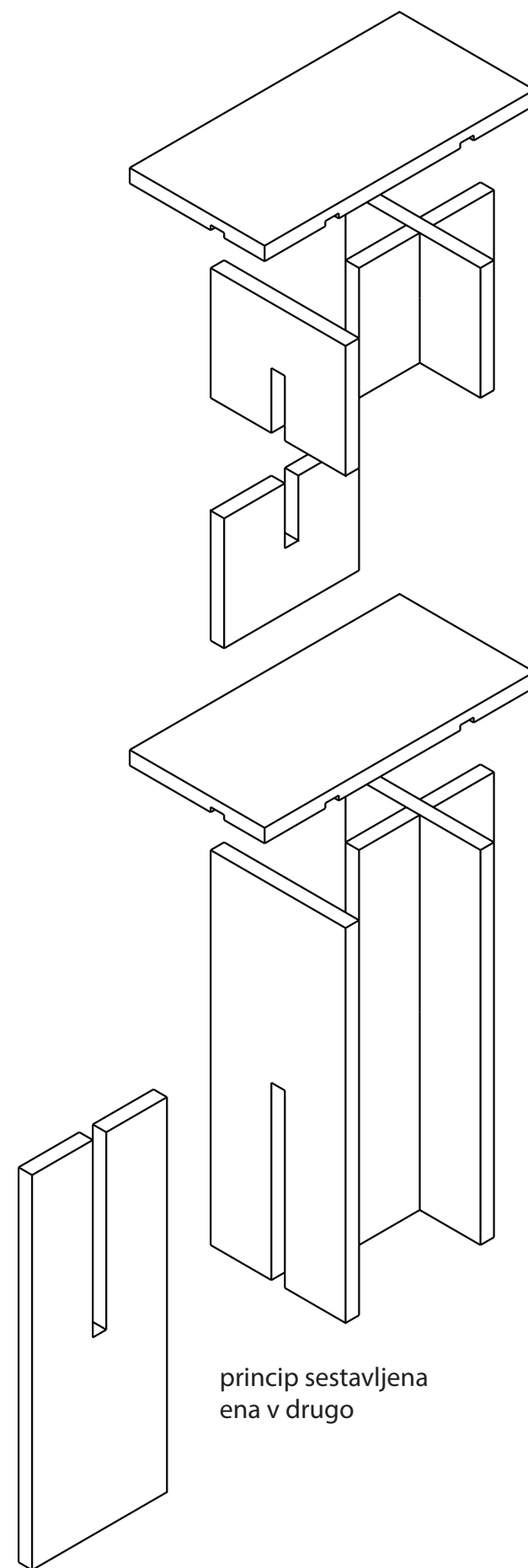
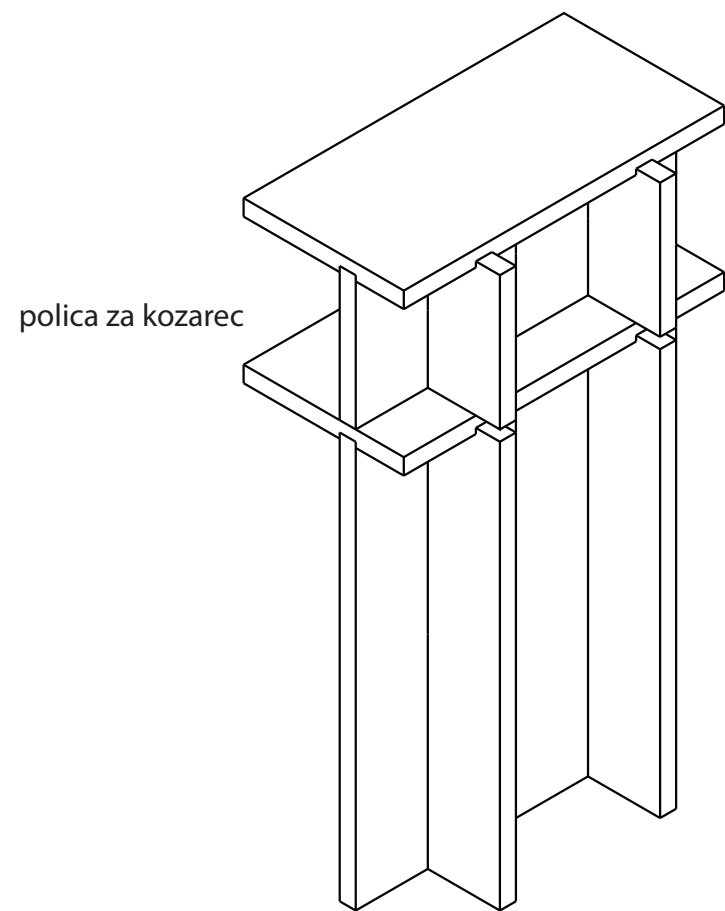

govorniški oder 1:10

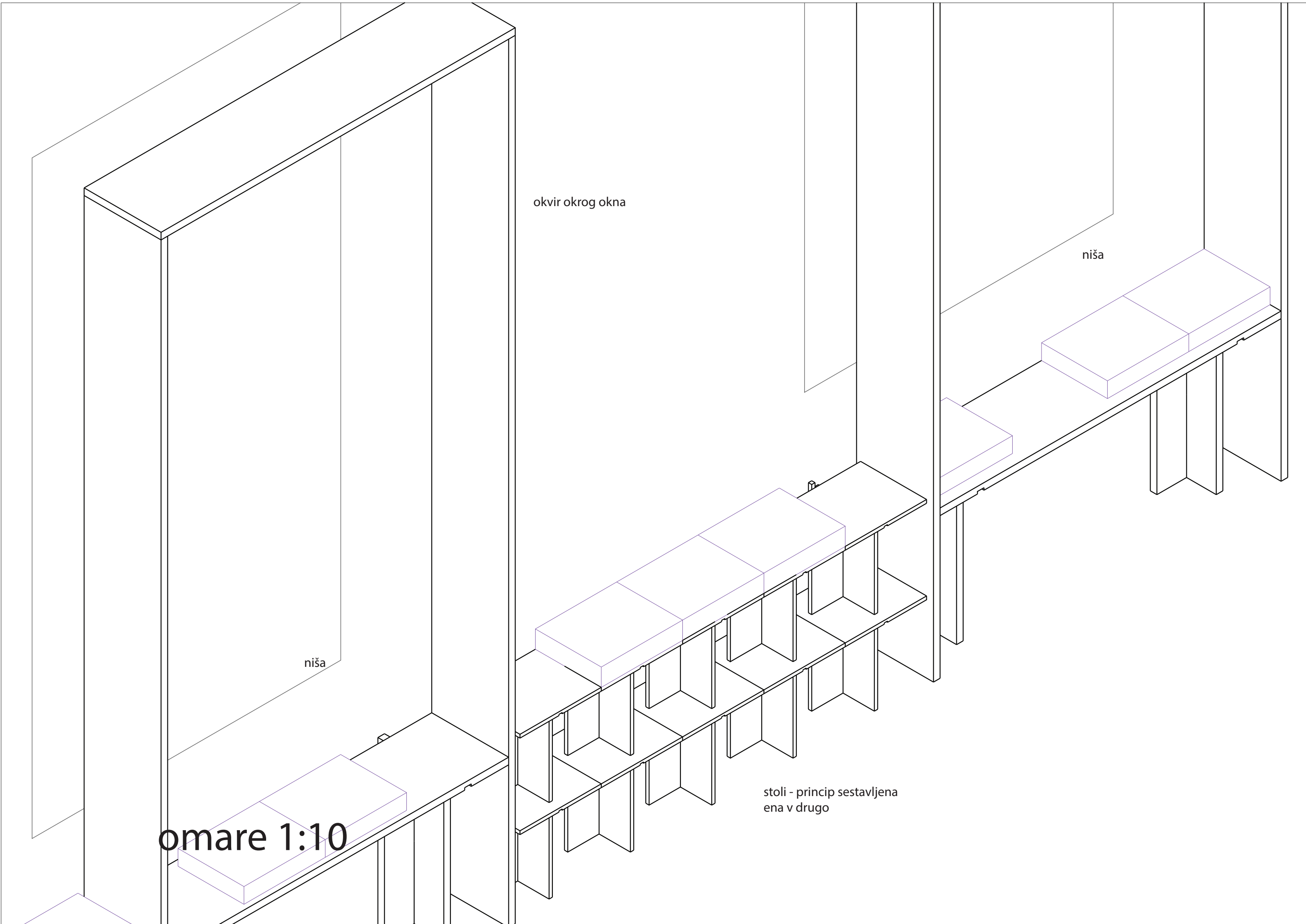

okvir okrog okna

niša

niša

omare 1:10

stoli - princip sestavljen
ena v drugo

B

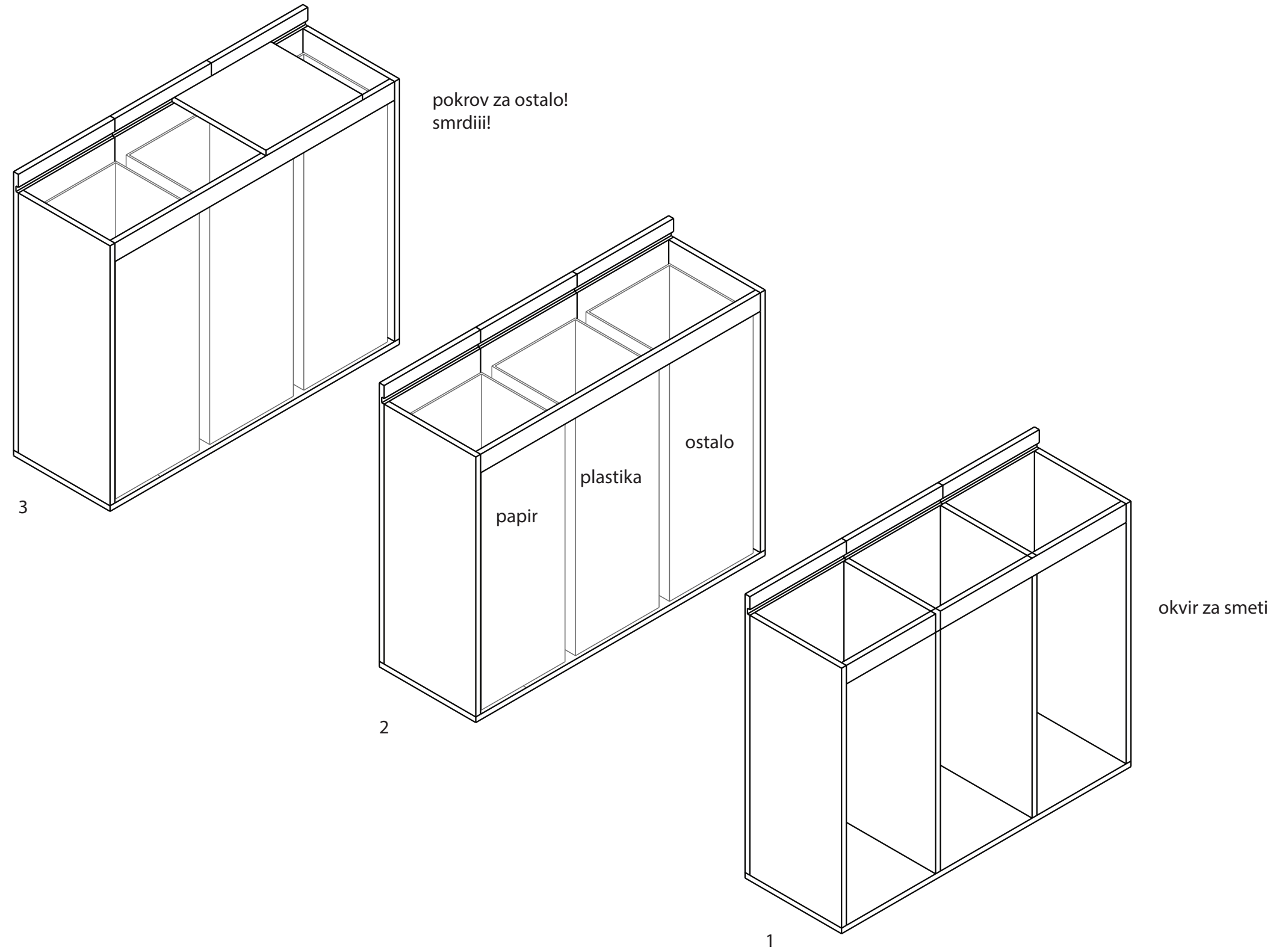

smeti 1:10

B

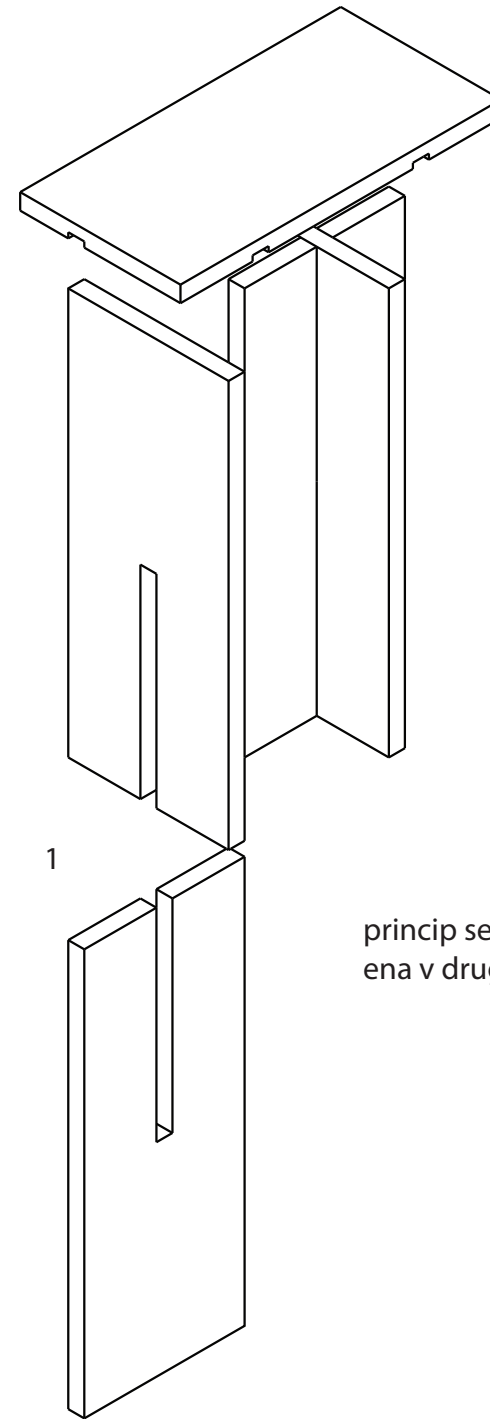
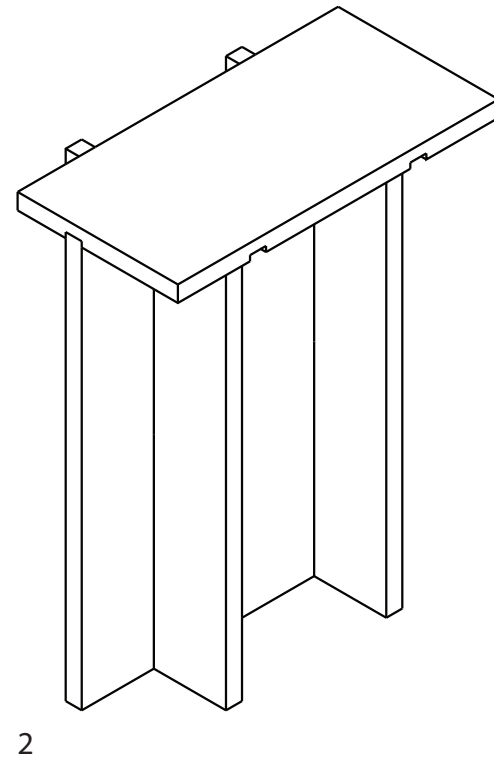
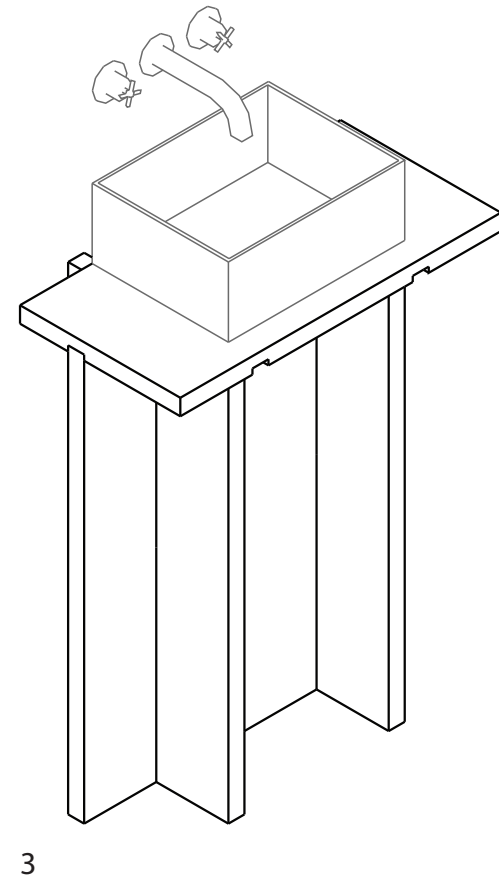

princip sestavljena
ena v drugo

umivalnik 1:10



